

56PA
57BYG

步进行星齿轮减速电机
PLANET GEAR STEPPER MOTOR

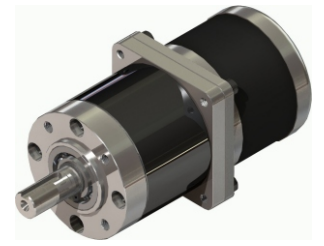

● 齿轮箱参数(Gear Box Data):

减速比/Reduction Ratio(1:X)	4.1	4.9	16.6	20.0	24.1	67.5	81.4	98.1	118.5
精确减速比/Exact Reduction Ratio(X:1)	$\frac{57}{14}$	$\frac{54}{11}$	$\frac{3249}{196}$	$\frac{1539}{77}$	$\frac{2916}{121}$	$\frac{185193}{2744}$	$\frac{87723}{1078}$	$\frac{83106}{847}$	$\frac{157464}{1331}$
传动级数/Number of gear trains(#)	1	1	2	2	2	3	3	3	3
最大允许力距/Max. Permissible Torque (kg.cm)	130		160			200			
瞬间允许力距/Moment Permissible Torque(kg.cm)	390		480			600			
齿轮箱长度/ Gear Box Length {L (mm)}	43		55			67			

● 马达参数(Motor specifications):

电机型号	步距角	机身长度	相电压	相电流	相电阻	相电感	静力矩	引线
Motor Model #	Step Angle	Length (Ld)	Rated Voltage	Rated Current	Phase Resistance	Phase Inductance	Holding Torque	Lead Wire
	(°)	(mm)	(V)	(A)	(Ω)	(mH)	(Kg.cm)	(#)
57BYGH41(M)-144-4A/B	1.8/0.9	41	4.1	1.44	2.85	5.4	5.5	4
57BYGH51(M)-144-4A/B	1.8/0.9	51	4.74	1.44	3.3	8.2	10	4
57BYGH56(M)-100-6A/B	1.8/0.9	56	7	1.00	7.6	10	9	6
57BYGH56(M)-280-4A/B	1.8/0.9	56	2.52	2.80	0.9	2.5	12.5	4
57BYGH76(M)-200-6A/B	1.8/0.9	76	5	2.00	2.25	3.6	13.5	6
57BYGH76(M)-280-4A/B	1.8/0.9	76	3.16	2.80	1.13	3.6	18.9	4

说明: A:单出轴; B:双出轴。
Note: A: single shaft, B: double shaft
M=0.9 Step Angle

● 外形和安装尺寸(Dimensions):

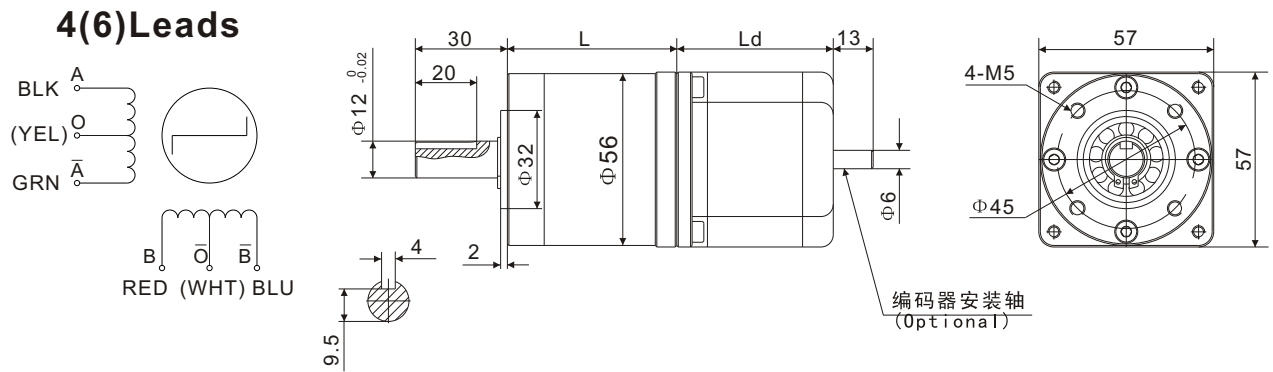

● 型号定义(Product Code):

机座号	行星齿轮	减速比	马达机座	混合式	机身长度	相电流	引线数	出轴
56	PA	16G	- 57	BYG	41 - 038	- 6	B	
Frame size	Planetary	Gear Ratio	Motor size	Hybrid Motor	Body Length	Hybrid Motor	#leads	Shaft
56=Φ56		16=16:1	57=57X57		41=41mm	038=0.38A	6=6leads	A=single B=double