

IET30 Incremental Optical Encoder

Features:

- 2 channel quadrature outputs
- Optional index (3rd channel)
- Low cost, small size
- 50 to 1024 cycles per revolution (CPR)
- 200 to 4000 pulses per revolution (PPR)
- Fit shaft diameters: 2mm to 10mm



Applications:

The IET provides motion detection at a low cost, making them ideal for high volume applications. Typical applications include PM DC Motors, Brushless DC Motors, and Stepping Motors.

Description:

The IET is high performance, cost-effective, two/three channel optional incremental housed encoders. These encoders emphasize high reliability, high resolution and easy assembly. The IET encoders contain Agilent's transmissive incremental encoder module (HEDS-9100/9140) and a code wheel.

Waveform:

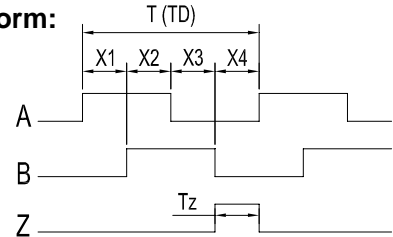

Mechanical Drawing:

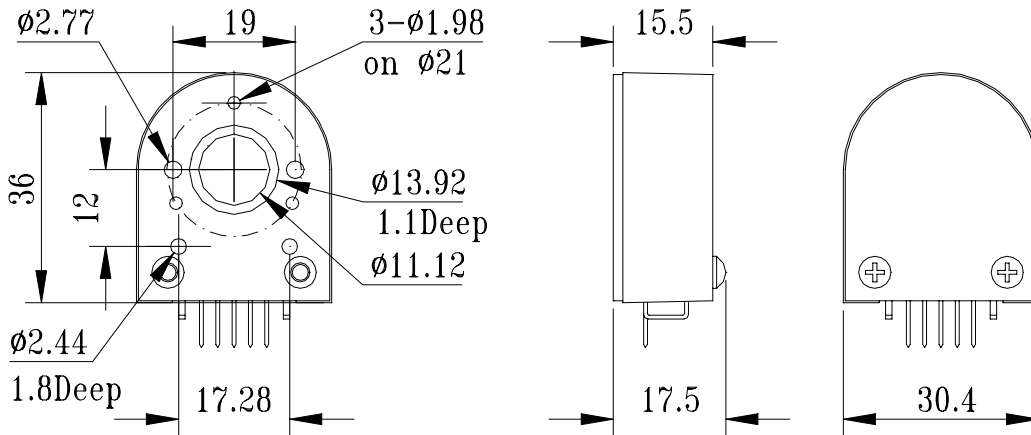

Recommended Operating Conditions:

Supply Voltage	5.0 ± 0.5V
Supply Current HEDS-9100	40mA Max.
Supply Current HEDS-9140	85mA Max.
Count Frequency	100kHz Max.
Load capacitance	100pF Max.
Temperature	0 ~ 85°C

Pin Description:

PIN	Description
1	Ground
2	Index
3	A Channel
4	+5VDC
5	B Channel

Ordering Information:

<u>IET</u>	<u>30</u>	-	<u>CPR</u>	-	<u>Shaft Dia.</u>	-	<u>Options</u>
Type	Frame size		100,200,256		3=3.00mm		I=Index(Z)
Transmissive	30=30mm		360,400,500		5=5.00mm		
			512,1000,1024		6.35=6.35mm		