

# 90mm

## V-SPUR GEARHEAD (增强正齿轮箱) w/ 80ZYT PM DC Motors (永磁直流流马达)



### ● GEARHEAD SPECIFICATIONS:

Gear Ratio	Stage	Eff.	Rated Load	Max. Load	Length
减速比	级数	效率	额定负载	最大负载	长度
1:X	#	%	Kg.cm	Kg.cm	mm
3 - 9	2	81	100	300	65
10 - 18	3	73	150	450	65
20 - 75	4	66	200	600	65
90 - 200	5	59	200	600	65

### ● Gearhead Dimensions:

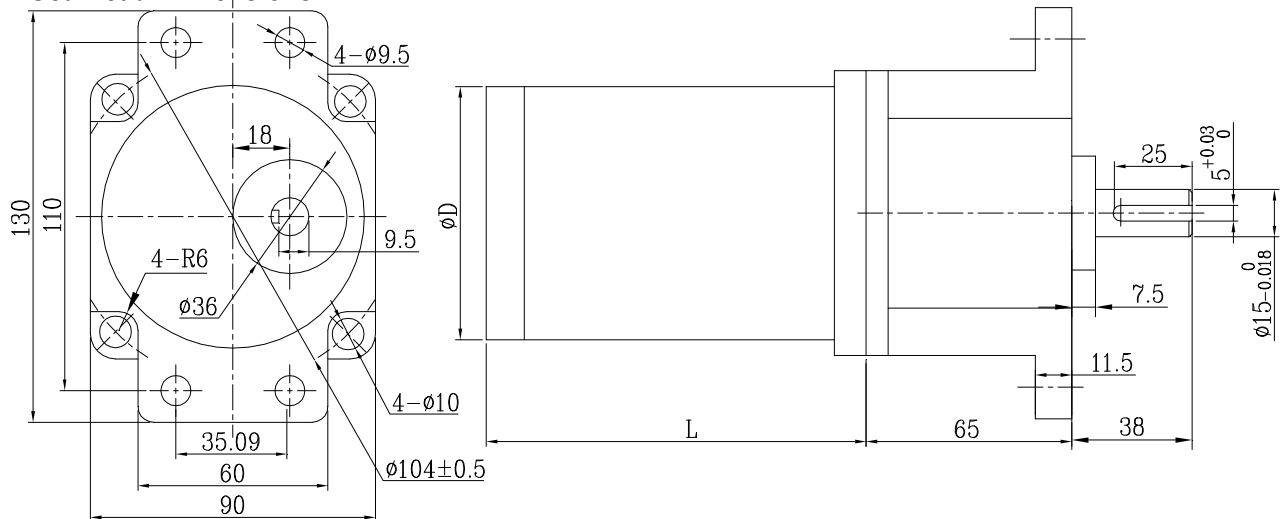

### ● MOTOR SPECIFICATIONS:

Model	Rated	No-load		Rated				Motor Length mm	
	Voltage	Current	Speed	Current	Speed	Torque			Power
	VDC	A	r/min	A	r/min	N.m	kg.cm		W
80ZYT125-12-32	12	2.2	3200	8.8	2600	0.206	2.1	56.0	125
80ZYT125-24-32	24	1.1	3200	4.4	2600	0.206	2.1	56.0	125
80ZYT145-12-32	12	2	3200	16.6	2600	0.441	4.5	120.1	145
80ZYT145-24-32	24	1	3200	8.3	2600	0.441	4.5	120.1	145

### ● GEARMOTOR SPECIFICATIONS: 90JB200KxxxG/ motor model

Y(IN-LB) = 0.867313\*X(Kg.cm)

Model	Gear Ratio	Y(IN-LB) = 0.867313*X(Kg.cm)																								
		3	3.6	5	6	7.5	9	10	12.5	15	18	20	25	30	36	40	50	60	75	90	100	120	150	180	200	
80ZYT 125- 12-32	Efficiency	11%	11%	11%	11%	11%	11%	73%	73%	73%	73%	66%	66%	66%	66%	66%	66%	66%	66%	59%	59%	59%	59%	59%	59%	
	Speed	RPM	367	722	520	433	347	289	260	208	173	144	130	104	87	72	65	52	43	35	29	26	22	17	14	13
	Load	N.m	1.51	1.61	1.8	1.01	1.2	1.51	1.50	1.88	2.25	2.71	1.7	1.41	1.01	1.8	1.4	1.81	1.1	0.7	10.9	12.1	14.6	18.2	19.6	19.6
80ZYT 125- 24-32	Efficiency	11%	11%	11%	11%	11%	11%	73%	73%	73%	73%	66%	66%	66%	66%	66%	66%	66%	66%	59%	59%	59%	59%	59%	59%	
	Speed	RPM	367	722	520	433	347	289	260	208	173	144	130	104	87	72	65	52	43	35	29	26	22	17	14	13
	Load	N.m	1.51	1.61	1.8	1.01	1.2	1.51	1.50	1.9	2.3	2.7	2.7	3.4	4.1	4.9	5.4	6.8	8.2	0.7	10.9	12.1	14.6	18.2	19.6	19.6
80ZYT 145- 12-32	Efficiency	10%	10%	10%	10%	10%	10%	73%	73%	73%	73%	66%	66%	66%	66%	66%	66%	66%	66%	59%	59%	59%	59%	59%	59%	
	Speed	RPM	367	722	520	433	347	289	260	208	173	144	130	104	87	72	65	52	43	35	29	26	22	17	14	13
	Load	N.m	1.0	1.2	1.7	1.1	1.6	3.2	3.2	4.0	4.8	5.8	5.8	7.3	8.7	0.7	1.1	1.4	1.7	9.1	19.6	19.6	19.6	19.6	19.6	19.6
80ZYT 145- 24-32	Efficiency	10%	10%	10%	10%	10%	10%	73%	73%	73%	73%	66%	66%	66%	66%	66%	66%	66%	66%	59%	59%	59%	59%	59%	59%	
	Speed	RPM	367	722	520	433	347	289	260	208	173	144	130	104	87	72	65	52	43	35	29	26	22	17	14	13
	Load	N.m	1.0	1.2	1.7	1.1	1.6	3.2	3.2	4.03	4.83	5.80	5.8	7.3	8.7	0.7	1.1	1.4	1.7	9.1	19.6	19.6	19.6	19.6	19.6	19.6